

- 1
- 2
- 3
- 4
- 5
- 6
- 7
- 8
- 9
- 10
- 11
- 12
- 13
- 14
- 15
- 16
- 17
- 18

STANDARD EXECUTIONS

AlSi 304 stainless steel cylindrical-head screw with hexagon socket and washer.

- **GN 355-ST**: black-oxide steel threaded body, hardened steel convex washer.

- **GN 355-NI**: AISI 303 stainless steel threaded body and convex washer.

FEATURES AND APPLICATIONS

GN 355 levelling elements are used to realise the levelling between two plates on machines, equipment etc., not on the same plane.

Firstly make the axial adjustment by screwing properly the threaded body by means of tool GN 355.1 (see page 1005).

Then tighten the screw that allows the support of the threaded body on the convex washer thus making the angular adjustment.

The values of w and x shown in the table, and those related to the static load have to be considered as reference values, which may differ depending on the type of application.

Further technical information available in "Operating instructions".



Application example

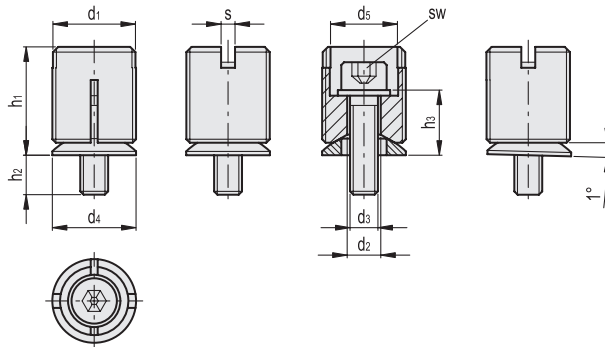
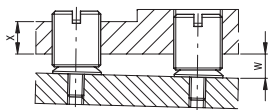

Conversion Table	
1 mm = 0.039 inch	
d2	
mm	inch
4.5	0.18
7	0.28
9	0.35
13	0.51
18	0.71

GN 355-ST

METRIC

Code	Description	d1	d2	d3	d4	d5	h1	h2	h3	sw	t	s	w	x	Static load [N]	Assembly tool	⚖
GN.21303	GN 355-M12X1-4.5-ST	M12X1	4.5	M4	12	9.1	19.1	10.9	9.1	3	3	2	8	8	4400	GN 355.1-12	11
GN.21307	GN 355-M18X1-7-ST	M18X1	7	M6	17	12.6	26.8	10.1	14.9	5	3	2	13	12	10000	GN 355.1-18	36
GN.21311	GN 355-M24X1.5-9-ST	M24X1.5	9	M8	24	19.6	31.1	11.3	18.7	6	6	4	17	16	29500	GN 355.1-24	63
GN.21315	GN 355-M30X1.5-13-ST	M30X1.5	13	M12	30	25.6	32.6	20.4	19.6	10	6	4	17	20	43000	GN 355.1-30	124
GN.21319	GN 355-M36X1.5-18-ST	M36X1.5	18	M16	36	31.6	45.7	15.8	24.2	14	6	4	21	24	91000	GN 355.1-36	228

GN 355-NI

INOX STAINLESS STEEL METRIC

Code	Description	d1	d2	d3	d4	d5	h1	h2	h3	sw	t	s	w	x	Static load [N]	Assembly tool	⚖
GN.21301	GN 355-M12X1-4.5-NI	M12X1	4.5	M4	12	9.1	19.1	10.9	9.1	3	3	2	8	8	4400	GN 355.1-12	11
GN.21305	GN 355-M18X1-7-NI	M18X1	7	M6	17	12.6	26.8	10.1	14.9	5	3	2	13	12	10000	GN 355.1-18	36
GN.21309	GN 355-M24X1.5-9-NI	M24X1.5	9	M8	24	19.6	31.1	11.3	18.7	6	6	4	17	16	29500	GN 355.1-24	63
GN.21313	GN 355-M30X1.5-13-NI	M30X1.5	13	M12	30	25.6	32.6	20.4	19.6	10	6	4	17	20	43000	GN 355.1-30	124
GN.21317	GN 355-M36X1.5-18-NI	M36X1.5	18	M16	36	31.6	45.7	15.8	24.2	14	6	4	21	24	91000	GN 355.1-36	228